

# Innovative Pulse Shaping for High-Performance Wireless TDMA

Balasubramaniam Natarajan, *Student Member, IEEE*, Carl R. Nassar, *Member, IEEE*, and Steve Shattil

**Abstract**—This letter introduces a novel pulse shaping scheme that enables receivers to demonstrate high performance in wireless fading environments. Called Carrier Interferometry pulse shaping, pulses are created by the superposition of  $N$  carriers. At the receiver, low probability-of-error performance is achieved by breaking the pulse into its frequency components and optimally recombining to create frequency diversity benefits. When implemented in a wireless TDMA system, simulations indicate 5–8-dB improvement at probability-of-error of  $10^{-2}$  over traditional Gaussian pulse shaping with decision feedback equalization (DFE(6,4)) in HT and TU channels.

**Index Terms**—Carrier interferometry, frequency diversity, pulse shaping, time-division multiple access.

## I. INTRODUCTION

**T**IME-DIVISION multiple access (TDMA) systems [e.g., Global System for Mobile Communications (GSM)] are extremely popular in wireless communication environments worldwide. To maintain acceptable performance in the presence of intersymbol interference (ISI) due to multipath, TDMA receivers in general and GSM receivers in particular may employ a decision feedback equalizer (DFE) [1].

In this letter, we introduce an exploitable frequency diversity into the TDMA architecture through an innovation in pulse shaping we call Carrier Interferometry (CI) pulse shaping. In CI/TDMA, each information bit modulates a pulse made up of  $N$  carriers equally spaced in frequency. At the receiver, instead of an equalizer, pulses are decomposed into their carriers and recombined to minimize noise and maximize diversity benefits. The BER performance of this new system is compared to that of a TDMA system employing Gaussian pulse shaping and a conventional DFE(6,4) and 5–8-dB performance benefits are demonstrated at probability of error of  $10^{-2}$ . These performance benefits come without cost in bandwidth or throughput. We believe that performance benefits result because receivers employing frequency domain processing better harness the energy scattered by the fading channel. That is, with time domain processing performed by digital matched filters and equalizers with a limited number of taps [e.g., DFE(6,4)], such processing experiences performance degradation that can be overcome by the proposed frequency domain processing.

Manuscript received March 1, 2001. The associate editor coordinating the review of this letter and approving it for publication was Dr. K. Zhang.

B. Natarajan and C. R. Nassar are with the Department of Electrical and Computer Engineering, Colorado State University, Fort Collins, CO 80523-1373 USA (e-mail: nbalsu@engr.colostate.edu; carln@engr.colostate.edu).

S. Shattil is with Idris Communications, Louisville, CO 80027 USA (e-mail: steve@idriscomm.com).

Publisher Item Identifier S 1089-7798(01)09046-9.

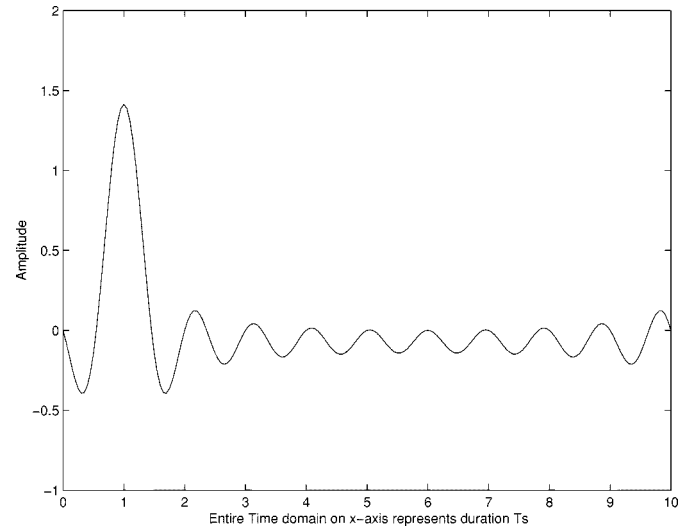

Fig. 1. CI pulse shape ( $N = 10$ ).

## II. CI PULSE SHAPING

The CI pulse is created by superpositioning  $N$  carriers equally spaced in frequency by  $\Delta f = 1/T_s$ , where  $N$  corresponds to the number of bits per slot, e.g., 148 in GSM; and  $T_s$  is the TDMA slot time (This  $\Delta f$  spacing ensures orthogonality among carriers). Thus, the CI pulse shape, implemented using IFFT's, corresponds to

$$h(t) = \sum_{i=1}^N A \cos(i2\pi\Delta ft) \quad (1)$$

where  $A = (\sqrt{1/N})(\sqrt{2}/T_s)$  is a constant that ensures a pulse energy of unity. Fig. 1 plots the pulse shape  $h(t)$  over slot time  $T_s$  (a delay of '1' is added for ease in presentation). As seen in Fig. 1, the duration of the pulse shape is limited to slot time  $T_s$  (576.6  $\mu$ s in GSM) and not bit duration  $T_b$  (3.69  $\mu$ s in GSM). Because the pulse corresponds to an interferometry pattern in time, we refer to it as the CI pulse shape.

To transmit a burst of bits, the  $k$ th bit in a user's burst,  $a_k$ , is modulated by the CI shape  $h(t - kT_b)$ , creating the total transmitted signal

$$s(t) = \left[ \sum_{k=1}^N a_k h(t - kT_b) \right] \cdot g(t). \quad (2)$$

Here,  $g(t)$  refers to a rectangular function of unity height and duration  $T_s$ , thereby limiting  $s(t)$  to one slot duration. It is important to note that time shifted pulses  $h(t - kT_b)$  and  $h(t -$

$nT_b$  ( $n \neq k$ ) are orthogonal to one another over slot duration  $T_s$ , i.e.

$$\int_0^{T_s} h(t - kT_b)h(t - nT_b)dt = 0 \quad (n \neq k). \quad (3)$$

This CI pulse shaping strategy creates TDMA signals made up of  $N$  separable frequency components. This feature is exploited at the receiver to benefit from frequency diversity.

### III. CHANNEL MODELING

Assuming fading channels consistent with the COST-207 standards [2] (where, e.g., in the HT channel, rms delay spread corresponds to  $5.03 \mu\text{s}$ ) and assuming bit duration consistent with GSM (i.e.,  $T_b = 3.69 \mu\text{s}$ ), the channel is characterized as a multipath fading channel. The multipath propagation in time translates into a frequency selectivity over the entire bandwidth. It is easily shown that each narrow-band carrier constituting the CI pulse shape experiences a flat (nonselective) fade. Specifically, with  $N$  carriers (making up the CI pulse shape) residing over the entire bandwidth,  $BW$ , each carrier undergoes a flat fade, with the correlation between the  $i$ th subcarrier fade and the  $j$ th subcarrier fade characterized by [3]

$$\rho_{i,j} = \frac{1}{1 + \left(\frac{f_i - f_j}{\Delta f_c}\right)^2} \quad (4)$$

where  $(f_i - f_j)$  indicates the frequency separation between the  $i$ th and the  $j$ th subcarriers and  $\Delta f_c$  is the coherence bandwidth. Generation of fades with correlation has been discussed in [4].

Hence, the received signal in the time domain is characterized by

$$r(t) = \sum_{k=1}^N a_k \sum_{i=1}^N \alpha_i A \cdot \cos(2\pi i \Delta f (t - kT_b) + \phi_i) g(t) + \eta_i(t) \quad (5)$$

where  $\alpha_i$  is the gain  $\phi_i$  the phase offset in the  $i$ th carrier of CI pulse shape (due to the channel fade). To simplify the analysis, exact phase synchronization is assumed.

### IV. RECEIVER DESIGN

The CI/TDMA receiver of Fig. 2 illustrates the detection of the  $j$ th bit,  $a_j$ . First, the CI pulse shape on which the bit  $a_j$  resides is separated into  $N$  carrier components (typically implemented as an FFT), outputting the decision vector  $\mathbf{r}_j = (r_{j,1}, r_{j,2}, \dots, r_{j,N})$  where  $r_{j,i}$  is the  $i$ th component and corresponds to

$$r_{j,i} = \frac{1}{N} \alpha_i a_j + \sum_{l=1, l \neq j}^N \frac{1}{N} \alpha_i a_l \cos(2\pi i \Delta f T_b (j - l)) + \eta_{j,i}. \quad (6)$$

The second term in (6) represents the presence (in the  $i$ th vector component) of the other  $N - 1$  bits in a user's burst; and  $\eta_{j,i}$  is a Gaussian random variable with mean 0 and variance  $N_o/2$ . In the absence of fading (i.e.,  $\alpha_i = 1$ ), a summation across vector components results in (1) the elimination of the second term (a result of the orthogonality condition in (3)) and (2) a

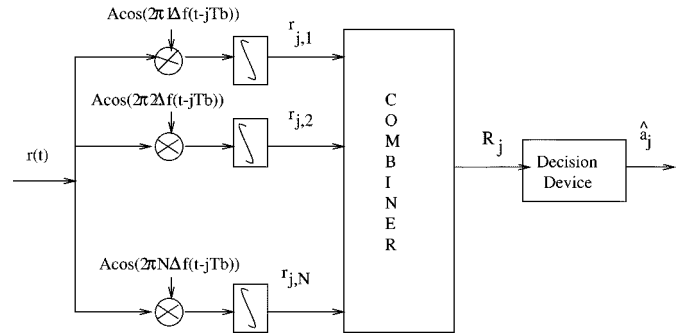

Fig. 2. CI/TDMA receiver structure.

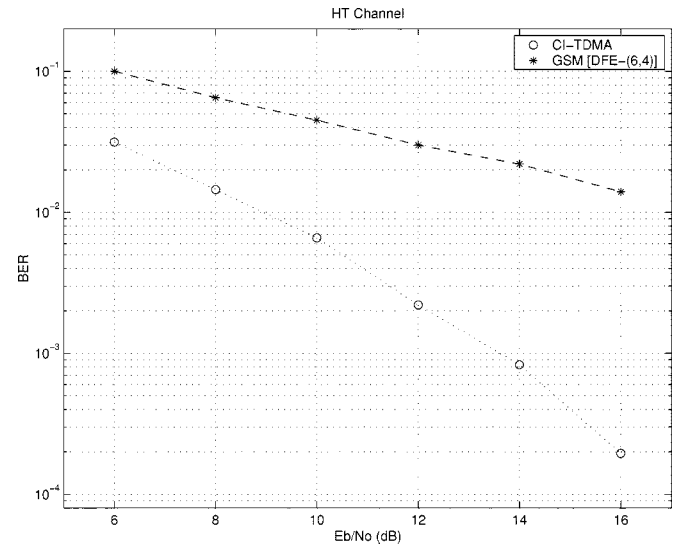

Fig. 3. BER comparison in HT channel.

maximization of the signal to noise ratio. However, in the presence of fading, the multi-carrier literature has shown that minimum mean square error combining (MMSEC) offers the best performance when combining the  $r_{j,i}$ 's to create a single decision statistic  $R_j$  [5]. MMSEC jointly minimizes the second term and the noise term in (6) by the combining

$$R_j = \sum_{i=1}^N r_{j,i} \cdot \left[ \frac{\alpha_i}{(\alpha_i^2 \cdot K_{i,j} + \frac{N_o}{2})} \right] \quad (7)$$

where  $K_{i,j}$  is a constant for a given  $i$  and  $j$  and corresponds to

$$K_{i,j} = \sum_{p=1}^N \cos(2\pi i \Delta f T_b (p - j))^2. \quad (8)$$

A hard decision device leads to a final decision on  $a_j$ ,  $\hat{a}_j$ .

### V. PERFORMANCE RESULTS

Figs. 3 and 4 present bit error probability (BER) versus SNR performance curves for the hilly terrain (HT) and typical urban (TU) channels [2] respectively. The dotted line (marked with circles) represents the CI/TDMA system results and the dashed line (marked with stars) represents a GSM system employing Gaussian pulse shaping with a DFE(6,4) receiver [1]. Both systems have identical slot duration, throughput and bandwidth. Specifically, both systems, each assuming an identical bit rate of

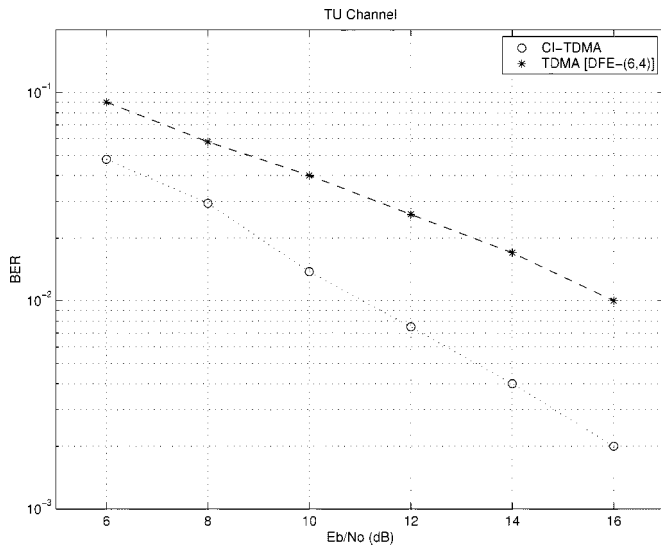

Fig. 4. BER comparison in TU channel.

$1/T_b$ , demonstrate the following bandwidth ( $BW$ ) occupancy: for CI/TDMA,  $BW = N \cdot \Delta f = N \cdot 1/NT_b = 1/T_b$ ; whereas for GSM with a Gaussian pulse shape and  $BT_b = 0.3$ ,  $BW \approx 1/T_b$ .

The new CI/TDMA scheme achieves more than 8 dB gain in the HT channel at probability of errors in the order of  $10^{-2}$ . In the TU channel, gains in the order of 5 dB are achieved at probability of errors of  $10^{-2}$ .

These results appear to show that the performance degradations that result due to limited number of taps in a digital matched filter and DFE(6,4) equalizer are overcome by a receiver which employs a frequency based processing. As the number of taps in the equalizer is increased, the performance of

the equalizer structure can be significantly improved. However, this comes at a significant cost in complexity. Here, without cost in bandwidth, throughput or slot duration, CI/TDMA provides an efficient low cost way of achieving high performance by exploiting the frequency domain through pulse shaping. Since it retains all the features of a TDMA system, all higher protocol levels currently in use for TDMA are applicable to CI/TDMA as well.

## VI. CONCLUSIONS

In this letter a novel pulse shaping method involving multiple carriers is applied to a TDMA architecture. This multi-carrier scheme does not require an equalizer at the receiver. Instead, using suitable combining strategies, the receiver performs frequency domain processing. Simulation results show that without cost in bandwidth, throughput or slot duration, significant improvement in performance is achieved when this architecture is applied to a mobile environment.

## REFERENCES

- [1] B. A. Bjerke, J. G. Proakis, M. K. Lee, and Z. Zvonar, "A comparison of decision feedback equalization and data directed estimation technique for the GSM system," in *IEEE 6th Int. Conf. on Universal Personal Communications*, 1997.
- [2] "Digital land mobile radio communications," Commission of the European Community, COST-Project 207, 1989.
- [3] W. Xu and L. B. Milstein, "Performance of multicarrier DS CDMA systems in the presence of correlated fading," in *IEEE 47th Vehicular Technology Conf.*, Phoenix, AZ, May 4-7, 1997, pp. 2050-2054.
- [4] B. Natarajan, C. R. Nassar, and V. Chandrasekhar, "Generation of correlated Rayleigh fading envelopes for spread spectrum applications," *IEEE Commun. Lett.*, vol. 4, pp. 9-11, Jan. 2000.
- [5] S. Hara and R. Prasad, "Overview of multi-carrier CDMA," *IEEE Commun. Mag.*, vol. 35, no. 12, pp. 126-133, Dec. 1997.